

S-420i™

Basic Description

FANUC Robotics' S-420i line of robots is engineered for maximum performance and reliability in the automotive body shop and is supported by our extensive application technology and service/parts network. The S-420i features a unique integrated controller, six-axis modular construction and a flexible, electric servo-driven design for high-speed and heavy payload processes.

S-420i, the Solution for:

- Automotive spot welding and body assembly
- General industrial spot welding
- Material handling

Benefits

- Work envelope allows processing of large fabrications
- Modular robot design allows conversion from one model to another
- Combined mechanical unit and robot controller reduces floor space, point-to-point wiring and installation costs
- Minimal mechanical/electrical parts increase reliability
- High motion speeds reduce time between welds
- 360° Axis 1 rotation
- User power/signal/air lines internal to arm for increased reliability
- Easy-to-learn and use application programming packages
- "Quick change" electronics cabinet reduces downtime to less than 15 minutes
- Low mass arm design allows high-speed positioning
- Proven arm design in over 13,000 S-420 robot installations

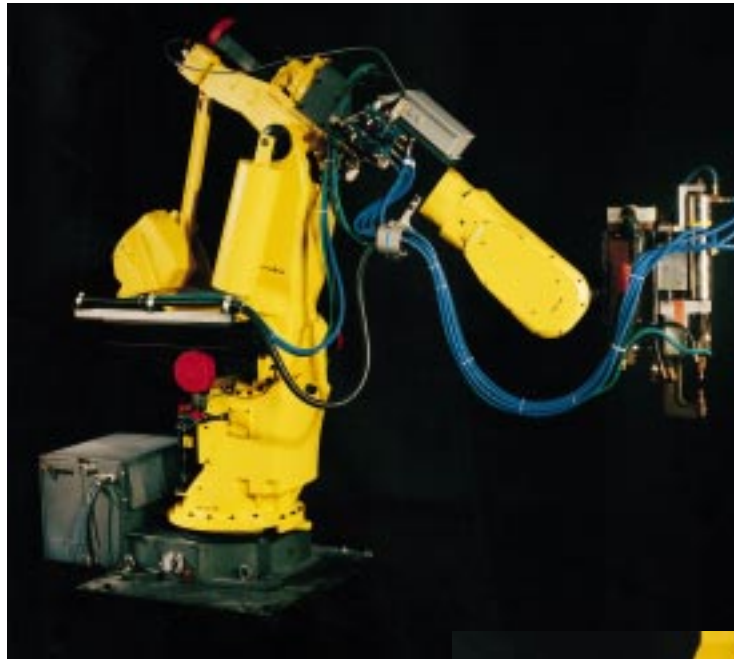

Flexibility Features

- Extension arm, heavy payload wrist, wedge pedestal, reduction ratio and balancer modules allow simple robot conversion to single point weld, rack mount, long arm or heavy duty types
- Flexible and expandable I/O system internal to controller
- Distributed I/O blocks to reduce wiring

Mechanical Features

- Mechanical construction provides precise positioning and high motion speed
- Direct drive on all axes results in higher reliability and reduced maintenance
- RV speed reducers provide smooth motion at all speeds and a long life
- Simple modular design with few components
- Sealed bearings and drives provide protection and improve reliability



- Absolute serial encoder positioning
- Wrist axis torque and inertia allows rated motion speed with large guns/tools
- Unique hollow RV speed reducers simplify cable routing
- Compact remote mount operator panel reduces aisle and floor space requirements
- Waist mounted forklift brackets can be used for peripheral and weld transformer mounting
- Compact arm option for close spacing of units

FANUC
Robotics

Isometric

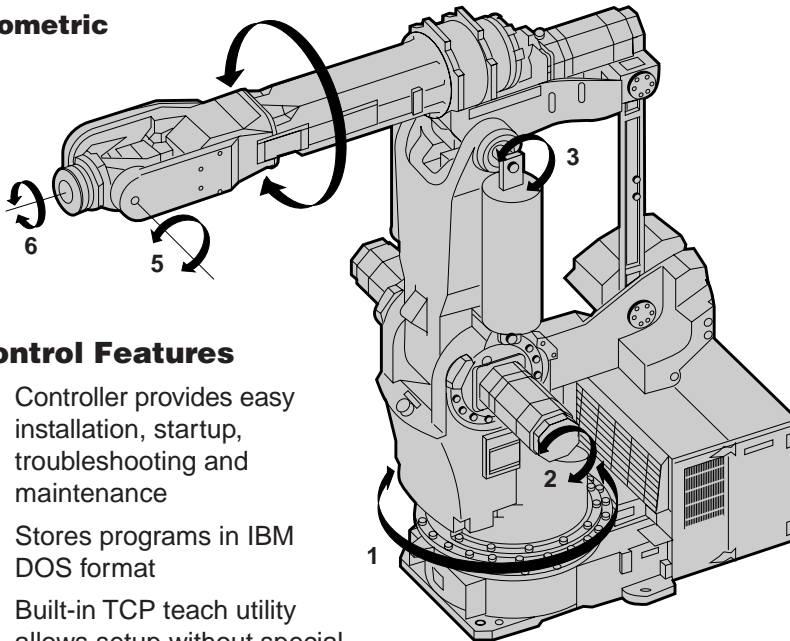

Control Features

- Controller provides easy installation, startup, troubleshooting and maintenance
- Stores programs in IBM DOS format
- Built-in TCP teach utility allows setup without special fixturing
- Easy-to-apply user multi-tasking programming environment
- Six-axis servo drive and single board control maximizes integration and reliability
- Distributed I/O blocks eliminate costly multi-conductor cables
- Common SYSTEM Robot Controller interface to PLC, peripheral control, valve packs, robot programs and training increase customers' ease-of-use
- Advanced TurboMove motion control increases throughput

Software Features

- Teach pendant uses menu-driven, plain English commands and process-specific, built-in functions
- English commands, comments, user-defined jog frames and consistent speed paths make setup and programming quick and easy
- Tool packages allow positional and speed adjustments during robot cycles
- SpotTool soft panel on teach pendant reduces hard wired buttons, switches and signals lights

- Other standard software features include:
 - Alarm logging and diagnostics
 - Simple robot setup
 - Production monitoring
 - File utilities
 - Menu windows
- Optional SpotWorks cell PC graphical interface supplements controller functionality and provides the following features:
 - Cause and recovery fault diagnostics
 - Three-dimensional path editor
 - PLC connectivity support
 - Weld controller network support
 - On-line manuals
 - Direct PC connection on plant network

Options

- Internal arm user I/O and power wiring and air tube
- Tool Frame adjustment
- Ethernet and RS-232 Communications
- Remote TCP programming and jogging control
- Remote cabinet mounting with 7m (23 ft.) or 14m (46 ft.) cables
- CSA approval option

Footprint

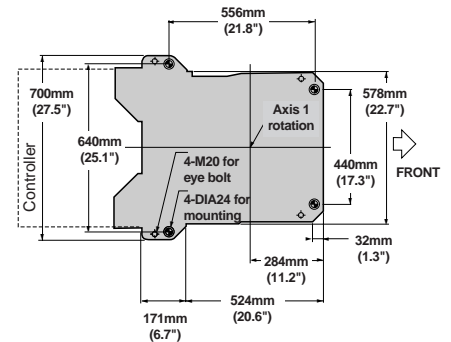

Mounting plate (FANUC std)

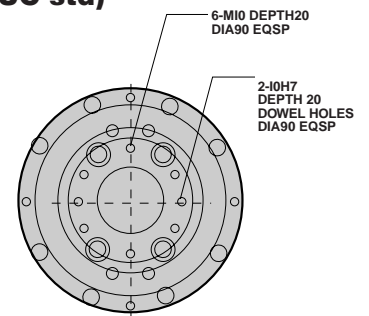

Mounting plate (ISO std)

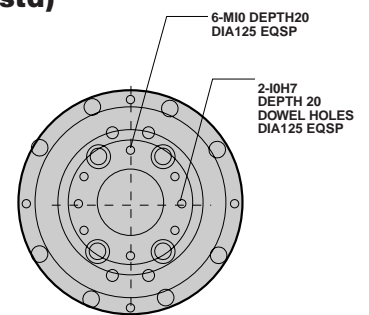

Operation box

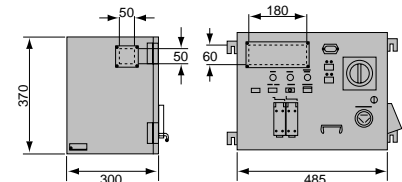

S-420i Product Line

Family of S-420i Robots

Model	Reach	Purpose
S-420iF	2.4m (7ft, 11in)	Floor mount
S-420iF	2.85m (9 ft, 4 in)	Floor mount
S-420iL	3.0m (9 ft, 9 in)	Long arm
S-420iS	2.25m (7 ft, 5 in)	Single point
S-420iW	2.4m (7 ft, 11 in)	Heavy duty
S-420iR	3.11m (10 ft, 2 in)	Rack std duty
S-420iR	3.11m (10 ft, 2 in)	Rack hvy duty

S-420i Dimensions

S-420i F/W

Top

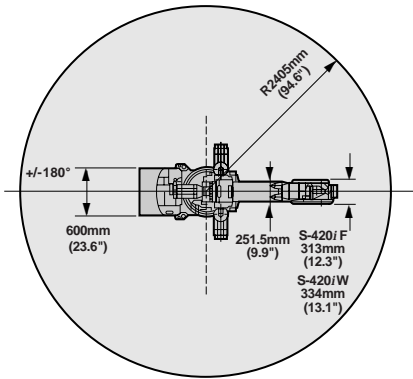

Side

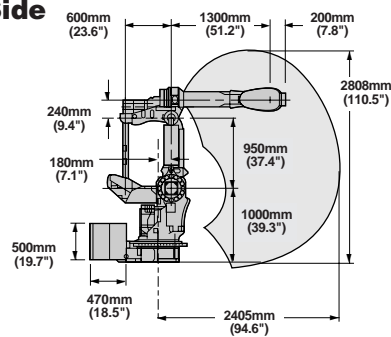

S-420i L

Top

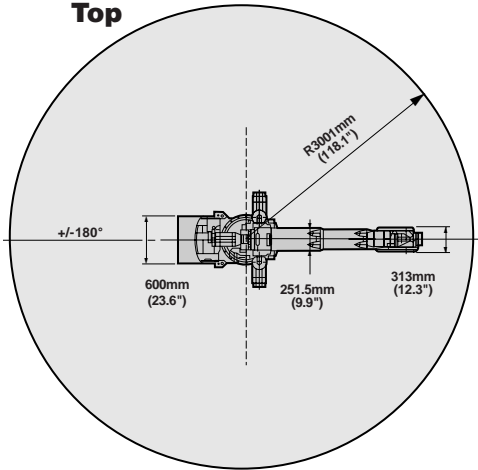

Side

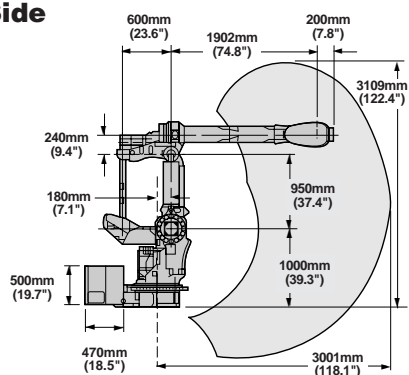

S-420i S

Top

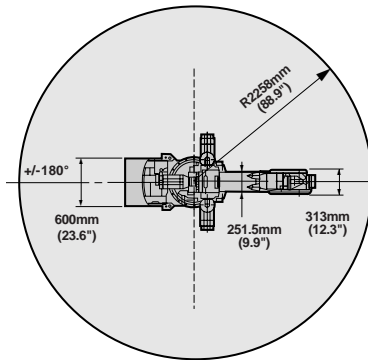

Side

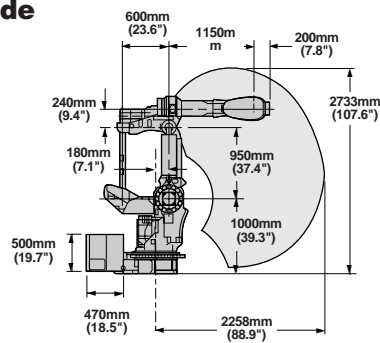

S-420i F

Top

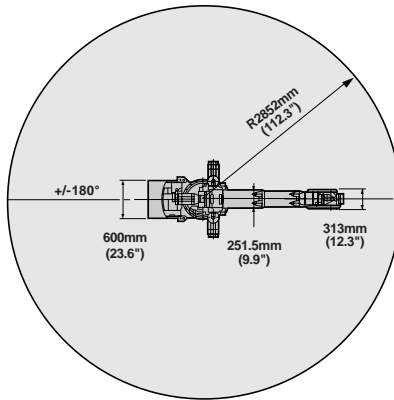

Side

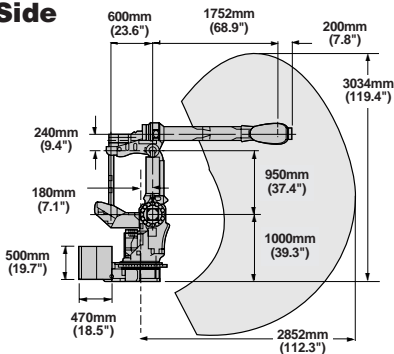

S-420i R

Top

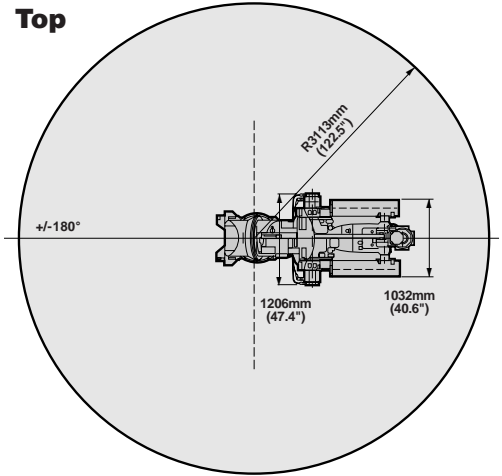

Side

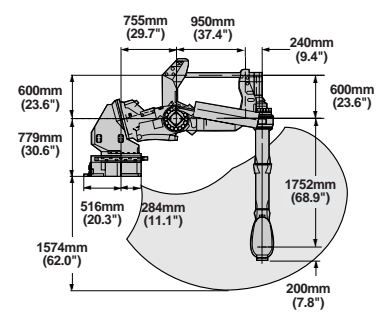

Front

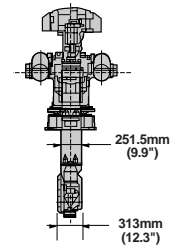

Front

for S-420i F/W/L/S

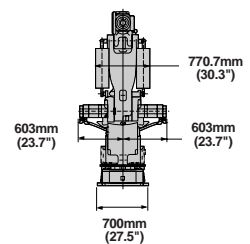

Scale
1/100"

S-420i Specifications

Items	S-420i F	S-420i F	S-420i F	S-420i L	S-420i S	S-420i W	S-420i W	S-420i W
Maximum reach	2.40m	2.85m	3.0m	3.00m	2.25m	2.40m	2.85m	2.40m
Load capacity	120kg (265 lbs)	120kg (265 lbs)	120kg (265 lbs)	75kg (165 lbs)	80kg (176 lbs)	155kg (342 lbs)	155kg (342 lbs)	175kg (386 lbs)
Axis 1	Range Speed	360° 100°/sec	360° 90°/sec	360° 100°/sec	360° 70°/sec	360° 90°/sec	360° 90°/sec	360° 90°/sec
Axis 2	Range Speed	142° 110°/sec	142° 100°/sec	142° 110°/sec	142° 110°/sec	142° 100°/sec	142° 100°/sec	142° 100°/sec
Axis 3	Range Speed	135° 100°/sec	135° 90°/sec	135° 100°/sec	135° 100°/sec	135° 75°/sec	135° 75°/sec	135° 75°/sec
Axis 4	Range Speed	600° 210°/sec	600° 210°/sec	600° 210°/sec	480° 210°/sec	600° 140°/sec	600° 140°/sec	600° 140°/sec
Axis 5	Range Speed	260° 150°/sec	260° 150°/sec	260° 150°/sec	260° 150°/sec	260° 110°/sec	260° 110°/sec	260° 110°/sec
Axis 6	Range Speed	720° 210°/sec	720° 210°/sec	720° 210°/sec	720° 210°/sec	720° 140°/sec	720° 140°/sec	720° 140°/sec
Moments	Axis 4	60kgf • m	60kgf • m	60kgf • m	53kgf • m	86kgf • m	86kgf • m	90kgf • m
	Axis 5	60kgf • m	60kgf • m	60kgf • m	54kgf • m	86kgf • m	86kgf • m	90kgf • m
	Axis 6	30kgf • m	30kgf • m	30kgf • m	27kgf • m	50kgf • m	50kgf • m	52kgf • m
Load	Axis 4	306kgf • cm • sec ²	306kgf • cm • sec ²	306kgf • cm • sec ²	387kgf • cm • sec ²	486kgf • cm • sec ²	486kgf • cm • sec ²	472kgf • cm • sec ²
	Axis 5	306kgf • cm • sec ²	306kgf • cm • sec ²	306kgf • cm • sec ²	387kgf • cm • sec ²	486kgf • cm • sec ²	486kgf • cm • sec ²	472kgf • cm • sec ²
	Axis 6	77kgf • cm • sec ²	77kgf • cm • sec ²	77kgf • cm • sec ²	104kgf • cm • sec ²	164kgf • cm • sec ²	164kgf • cm • sec ²	158kgf • cm • sec ²
Repeatability	Axis 6	±0.4mm (±0.016")	±0.4mm (±0.016")	±0.4mm (±0.016")	±0.4mm (±0.016")	±0.4mm (±0.016")	±0.4mm (±0.016")	±0.4mm (±0.016")
Mounting method	Upright	Upright	Upright	Upright	Upright	Upright	Upright	Upright
Mechanical brakes	All axes	All axes	All axes	All axes	All axes	All axes	All axes	All axes
Weight	1500 kg (3300 lbs)	1600 kg (3520 lbs)	1600 kg (3520 lbs)	1600 kg (3520 lbs)	1500 kg (3300 lbs)	1500 kg (3300 lbs)	1600 kg (3520 lbs)	1500 kg (3300 lbs)

Items	S-420i R	S-420i R	S-420i R
Maximum reach	3.11m	3.11m	3.11m
Load capacity	100kg (220 lbs)	120kg (265 lbs)	155kg (342 lbs)
Axis 1	Range Speed	360° 100°/sec	360° 90°/sec
Axis 2	Range Speed	123° 100°/sec	123° 100°/sec
Axis 3	Range Speed	106° 100°/sec	106° 75°/sec
Axis 4	Range Speed	600° 210°/sec	600° 140°/sec
Axis 5	Range Speed	260° 150°/sec	260° 110°/sec
Axis 6	Range Speed	720° 210°/sec	720° 140°/sec
Moments	Axis 4	57kgf • m	60kgf • m
	Axis 5	57kgf • m	60kgf • m
	Axis 6	29kgf • m	30kgf • m
Load	Axis 4	337kgf • cm • sec ²	306kgf • cm • sec ²
	Axis 5	337kgf • cm • sec ²	306kgf • cm • sec ²
	Axis 6	86kgf • cm • sec ²	77kgf • cm • sec ²
Repeatability	Axis 6	±0.4mm (±0.016")	±0.4mm (±0.016")
Mounting method	Rack	Rack	Rack
Mechanical brakes	All axes	All axes	All axes
Weight	1700 kg (3740 lbs)	1700 kg (3740 lbs)	1700 kg (3740 lbs)



FANUC Robotics offers complete S-420i application dressout featuring:

- Maintainability
- Reliability
- Unique configurations

FANUC

Robotics

FANUC Robotics North America
3900 W. Hamlin Road
Rochester Hills, MI 48309-3253
Phone (248) 377-7000
Fax (248) 377-7366

Charlotte, NC
 Phone (704) 596-5121
 Toronto, Canada
 Phone (905) 812-2300

Chicago, IL
 Phone (630) 876-5600
 Montréal, Québec
 Phone (450) 492-9001

Cincinnati, OH
 Phone (513) 754-2400
 Mexico City, Mexico
 Phone (52-5) 611-5998

Los Angeles, CA
 Phone (949) 595-2700
 Aguascalientes, Mexico
 Phone (52-4) 973-0453

Toledo, OH
 Phone (419) 866-0788
 Sao Paulo, Brazil
 Phone (55)(11) 3955-0599

web page: <http://www.fanucrobotics.com>

©1998 FANUC Robotics North America, Inc. All rights reserved.

OM 05-98 FANUC ROBOTICS LITHO IN U.S.A.